

SAFETY BULLETIN

SETTING OUTRIGGERS TO PREVENT ACCIDENTS II - SHORTTRIGGERING



AMERICAN CONCRETE
PUMPING ASSOCIATION

WWW.CONCRETEPUMPERS.COM

*Copyright ©2010 v1.01 ACPA – All rights reserved
Manufacturer's recommendations supersede any
and all information provided by the ACPA.*



Safety Bulletin

Setting outriggers to prevent accidents II

Shortrigging

Shortrigging

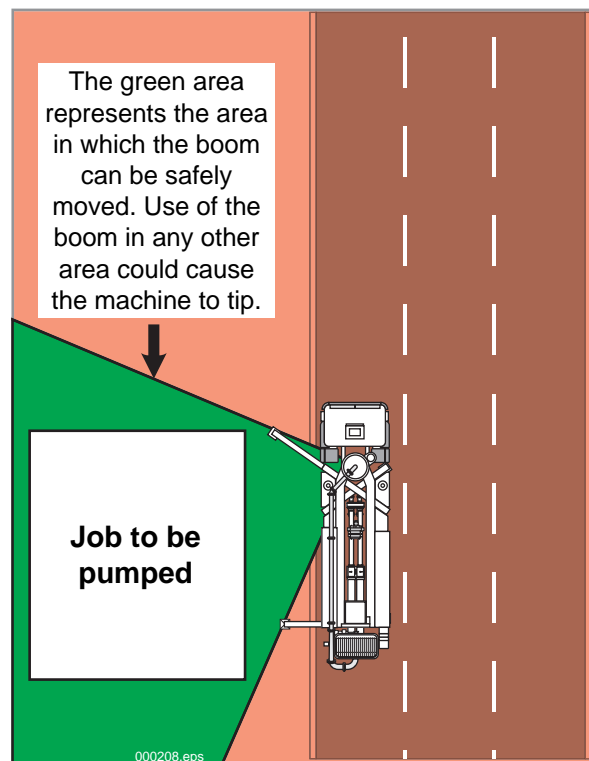

Figure 1
Shortrigging

“Shortrigging” describes the act of not extending the outriggers on the side away from the pour (Figure 1). Shortrigging is not recommended, but under certain conditions it may be required, and can be done safely if proper procedures are followed. If it is not possible to extend the outriggers on the side **away from the pour**, the unit can be set-up with the outriggers jacked down but not extended.

To avoid a tipping accident while shortrigged, you must follow a few rules:

- Have a qualified person document that shortrigging is required.
- Whenever possible, completely extend the outriggers.
- *Never* shortrig the machine on the side of the pour.
- Do not position the boom outside the center lines of the extended outriggers. The unit can tip when the center of gravity is beyond the extended outriggers.
- The manufacturer’s or a qualified person’s documented procedures are to be followed.
- Remember that not all of the outriggers are extended. Forgetting this fact is the most frequent cause of accidental tipping.

The following steps will help you to shortrig in the safest possible manner:

1. Before extending any outrigger, check which way the hydraulic hoses are wrapped in the turret. You must be able to unfold to the side with fully extended outriggers without moving the boom to the side with retracted outriggers (Figure 2).
2. If the boom is folded up on the wrong side you will need to fully extend the outriggers while you raise the boom and swing it around 360° to put it back in the cradle, then retract the outriggers which require shortrigging. Move the pump to a safe area to do this, if necessary.
3. Fully extend and jack the outriggers on the side of the pour (Figure 1). Use proper cribbing for the soil conditions.
4. **Do not partially extend** the outriggers on the side of the unit opposite the pour for the reasons shown on the following page.

They should, however, be jacked to provide stability.

5. After raising the boom from the cradle, do not *unfold* the boom until you have rotated to the area between the fully extended and jacked outriggers. The boom may then be unfolded and the tip hose released or attached.
6. At no point during the pour should the boom be moved outside the area between the center lines of the fully extended outriggers (Figure 1).
7. Upon completion of the pour, the cleanout ball should be inserted and sucked back, and the boom should be folded up completely, all the while staying on the same side as the fully extended outriggers, before slewing back toward the cradle.
8. Do not retract the extended outriggers until the boom is in the travel position.

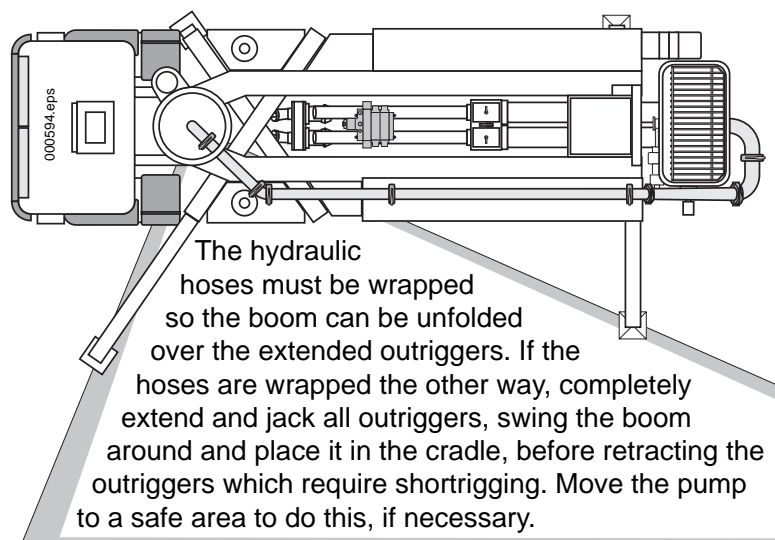

Figure 2
Check hydraulic hoses before unfolding

Do not partially extend outriggers

Structural damage could result (Figure 3 and Figure 4)

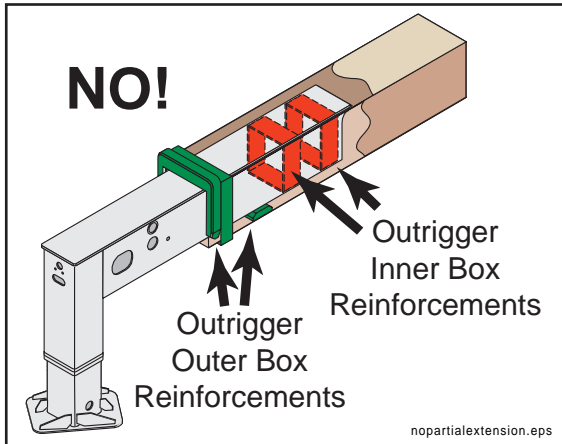

Figure 3

Transparent outrigger shows reinforcement areas (curved outriggers have the same limitations)

CAUTION

Structural damage to outriggers is possible. Do not jack outriggers unless they are either fully extended or fully retracted.

000467.eps

Partial extension of telescoping outriggers is not acceptable at any time. Jacking the outriggers while they are in any position other than fully extended or fully retracted could cause structural damage to the outrigger outer box and/or the inner box (Figure 3).

The three illustrations shown in Figure 4 explain the configurations of the outrigger in all positions.

Remember that in configuration number 1, the boom must *never* be extended over a retracted outrigger.

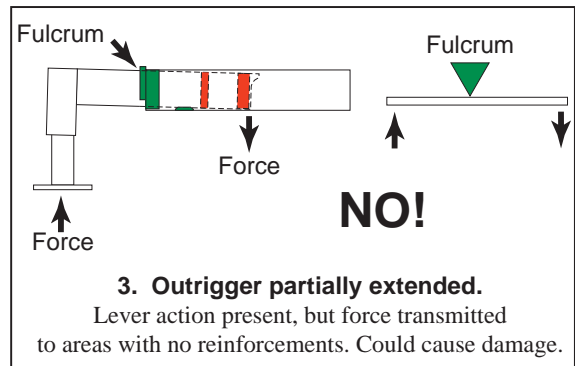
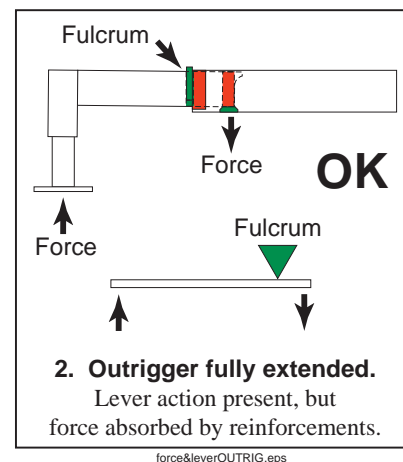
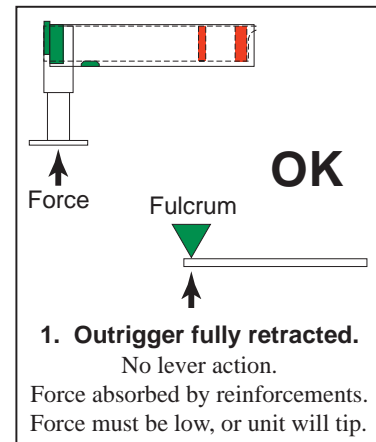

Figure 4

Examples of outrigger reinforcements in three different configurations

Tipping and Blocking Traffic

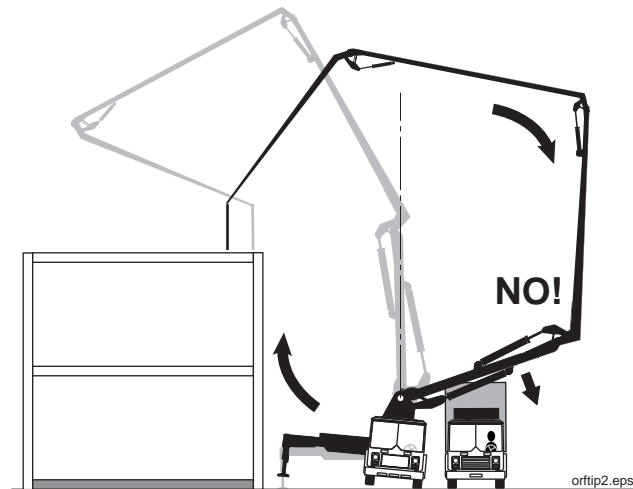

Figure 5
Danger of tipping if over center boom is retracted too far.

With any boom that can go over center, you must be careful to not retract #1 so far that the center of gravity will shift to the shortrigged side. In addition to the tipping hazard, the boom should never be placed in an area that will obstruct traffic (Figure 5).

Responsibilities

Contractors

- One of the things a contractor can do to help is to order the right size boom:
 - If the boom is too small, for example, he may have to set up too close to an excavation to reach the pour.
 - If the boom is too large, it will require much more cribbing than a smaller unit, and will require a larger set-up area.
- Have a place prepared for the pump before it arrives on the job.
- Inform the operator of backfilled areas, soft or muddy areas, or underground obstructions.
- Have cribbing nearby the set-up area prior to the pump's arrival (including steel sheets if the soil is known to be bad).
- Monitor the set-up. Don't let the operator cut corners or take chances.

Dispatcher

The dispatcher can help by communicating with the contractor when he calls to order the pump, and:

- Send the size pump that is needed, if available.
- If availability causes you to send a unit that is too big or too small, warn of possible complications.
- Ask about soil conditions, underground obstructions, and traffic considerations.

Operator

The operator is ultimately in charge and must make good decisions regarding set-up including:

- Know restrictions of boom movement caused by shortrigging and never exceed them.
- Partial extension is not allowed on extendable outriggers.
- Keep people out from under the boom whenever practical.

This document is intended to supplement, but not supersede the manufacturer's applicable instructions.

- By Danny Mace and Robert Edwards,
Edited by the ACPA.



AMERICAN CONCRETE PUMPING ASSOCIATION
606 ENTERPRISE DRIVE | LEWIS CENTER, OH 43035
P: 614.431.5618
WWW.CONCRETEPUMPERS.COM